

Radio Station Log Usage

Radio Station Logs

All communicators keep logs. Relays (if any needed) and command post operators maintain *Radio Station Logs*. Written *Field Team Message Forms* serve as a log for Field teams. Windshield Teams use the *Windshield Survey Messages Log*.

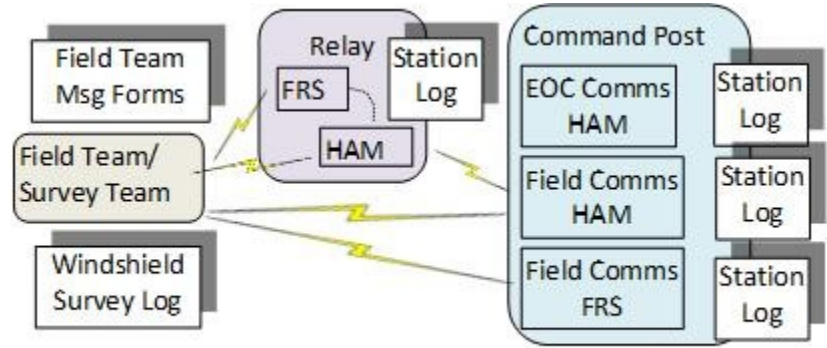

Radio Station Log Sample

Incident: <u>Demo</u>	Date: <u>03/10/2021</u>	<u>Ham</u> / FRS Channel: <u>51</u>
Radio operator(s): <u>KK6NRV (Warren), W6GSM (Gary)</u>	Msg ID Prefix: <u>L51h</u>	Tactical call-sign: <u>Lar Rieu Net Control</u>

Msg ID	Date & Time	T o / F rom station	Optional Notes
	03/10/21 0800	T / F:	Station on the air with operator KK6NRV
	" 0802	T / F: Comms Chief	Check-in with Chief
	" 0810	T / F: L SAR 3	Do requested radio check with L SAR 3
L51h1	" 0911	T / F: L SAR 2	(record msg from Lar Rieu SAR 2)
L51h2	" 0914	T / F: L WS 9	
L12f1	" 0930	T / F: L Relay North	Relay from L SAR 4 on FRS Channel 12
	" 0932	T / F:	W6GSM takes over as station operator
L51h3	" 0934	T / F: L WS 9	

The Radio Station Log Entries

- The log is a history of comms transactions that may be used to establish if/when something happened.
- Entries are **PRINTED, not written**
- Messages from different field teams are logged in the order in which they are received regardless of team.
- Use a separate log for each radio channel.
- For messages received from field teams, you use the log to determine the next message number and create the Msg ID (see examples in the sample log above), you enter it on the log, you enter it on the three-part Field Team Message Form as Item 26, and you transmit it to the field team. Never skip Msg IDs. For example, written messages received in the Sugarloaf CERT Area on Ham Ch 83 would be Msg IDs like **S83h1, S83h2, S83h3**, etc.
- For EOC messages, CERO always creates their own flavor of Msg ID for both sending and receiving messages.

Actions to perform for different incoming traffic

- Field Team Message**
 - Transcribe an incoming Field Team Message to a three-part Field Team Message Form which must include Items 1-4. Check for completeness and consistency. Pull missing info from the sender.
 - Have a runner deliver the completed three-part Form to Plans.
- Windshield Survey Message**
 - Transcribe an incoming Windshield Survey Message to a three-part Field Team Message Form which must include Items 1, 3, 13 and 15.
 - Problem Code(s) in Item 15 must include the English translation. (e.g., "2C Water main break").*
 - Have a runner deliver the completed three-part Form to Plans.
- Relays**
 - Unable to reach the command post directly, a field team uses an FRS relay to send a message. The relay transcribes the message, assigns its next Msg ID, e.g., L12f1, and then transmits to the command post.
- Non-Message entries**
 - Enter succinct descriptions like "Radio Check," "Request for info," etc.