

# Legacy Walnut Creek

## Legacy Walnut Creek Exterior Signage Exhibit

**WEIDNER**  
ARCHITECTURAL  
SIGNAGE

5001 24th Street  
Sacramento CA 95822  
**916.452.8000**  
Fax 916.452.3331  
CA Lic. #559090  
NV Lic. #0040109

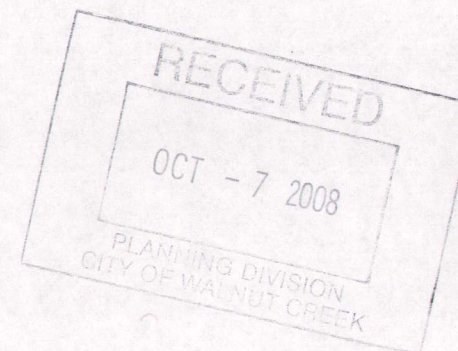

CITY OF WALNUT CREEK  
**PLANS APPROVED**  
AS CORRECTED  
Permit No. Y08-081 Date 10/16/08  
By Dhan

**LEGACY WALNUT CREEK**

PREVIOUSLY KNOWN AS: TOWER COURT PLAZA SIGN PROGRAM

The purpose of the signage program is to ensure that the integrity of the signage for Legacy Walnut Creek apartment and retail is presented with diversity and creativity while maintaining standards that achieve consistency throughout the project.

These Guidelines are established for Owner, City and Retail Tenants at Legacy Walnut Creek to provide a coordinated graphic system that communicates information in a distinctive and aesthetically pleasing manner. The visual consistency created by the criteria minimizes confusion and promotes an image of quality, which unites all of the individual establishments within Legacy Walnut Creek.

These Guidelines establish minimum standards that are reasonable and equitable while providing sufficient flexibility to accommodate the Retail Tenant's need to be recognized and marketable.

It is the responsibility of each Retail Tenant to submit design drawings of the proposed signage to the Legacy Walnut Creek Management and to the City of Walnut Creek for approval prior to the installation of any signage. The use of professional environmental graphic designers and professional signage companies is highly encouraged. Deviations from these Guidelines will only be considered if the overall purpose is to exceed the quality standards set forth herein. Deviations will require the review and approval by the City of Walnut Creek Design Review Committee and Legacy Walnut Creek Management.

**BACKGROUND:**

Legacy Walnut Creek consists of 109 residential units and over 10,000 sq. ft. of ground floor retail located at 1555 Riviera Avenue demised into 7 individual retail tenant spaces.

**PURPOSE:**

This request is to replace the existing Retail Tenant sign program and the existing apartment complex entry identification.

**RETAIL TENANT SIGNAGE:**

Individual tenant signage will be "push through" Lexan lettering within a routed, illuminated aluminum sign cabinet. The letters will have a dark brown face, matching the building's window and door trim and frosted transparent edges for light transmission. The sign cabinet dimensions are 16 feet in length by 2 feet in height by 7" deep. The sign cabinet will be painted metallic silver resembling brushed aluminum and securely mounted to the building fascia above each tenant's entrance doors.

The copy on the tenant signage is 8" tall and limited to one line of text (not to exceed 20 - 25 total characters or 15' - 6" in length). The font is limited to Bodoni bold -- no font substitutions, change of colors or logos will be accepted.

Tenant addresses will be white vinyl applied to the glass surface above the entrance doors measuring 9" in height.

Each tenant will have

**APARTMENT ENTRY SIGNAGE:**

The Legacy Walnut Creek apartment entrance signage will be "push through" Lexan lettering within a routed, illuminated aluminum sign cabinet. The letters will have a dark brown face, matching the building's window and door trim and frosted transparent edges for light transmission. The sign cabinet dimensions are 12' in length by 2' in height by 7" deep. The sign cabinet will be painted metallic silver resembling brushed aluminum and securely mounted to the building fascia above the apartment entrance doors.



5001 24th Street  
Sacramento CA 95822  
**916.452.8000**  
Fax 916.452.3331  
CA Lic. #559090  
NV Lic. #0040109

Project  
**Legacy • Walnut Creek**  
1555 RIVIERA AVENUE  
WALNUT CREEK, CA

Company  
Legacy Partners Residential

Work Order  
**31438**      Drawn By  
**DP**

Date  
09-25-08      Phase  
Permit Submittal

Revisions No.	Date	Phase	By
▲			
▲			
▲			
▲			
▲			
▲			
▲			
▲			

© Weidner Architectural Signage - No part of the above drawing(s), design, arrangements or ideas hereon shall be duplicated or used for any purpose whatsoever without the expressed written permission of the copyright holder.

Sign Type Description  
**EXTERIOR SIGNAGE PROGRAM**

Sign Type Code

Sheet No.

**01.0**

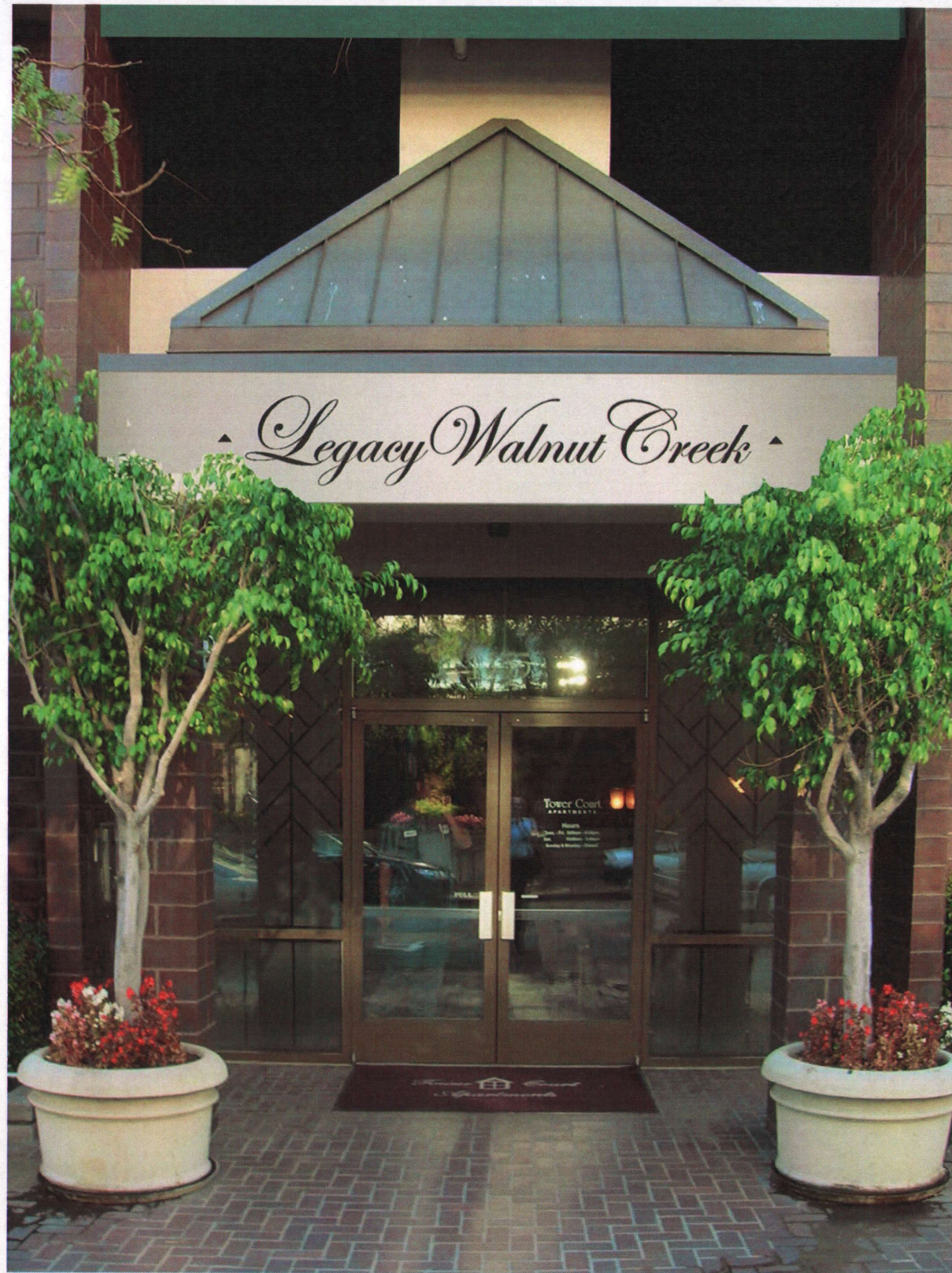

**WEIDNER**  
ARCHITECTURAL  
SIGNAGE

5001 24th Street  
Sacramento CA 95822  
**916.452.8000**  
Fax 916.452.3331  
CA Lic. #559090  
NV Lic. #0040109

Project  
**Legacy • Walnut Creek**  
1555 RIVIERA AVENUE  
WALNUT CREEK, CA

Company  
Legacy Partners Residential

Work Order  
**31438**

Drawn By  
**DP**

Date  
09-25-08

Phase  
Permit Submittal

Revisions No.	Date	Phase	By
▲			
▲			
▲			
▲			
▲			
▲			
▲			
▲			

© Weidner Architectural Signage - No part of the above drawing(s), design, arrangements or ideas herein shall be duplicated or used for any purpose whatsoever without the expressed written permission of the copyright holder.

Sign Type Description  
WALL MOUNTED ILLUMINATED  
APARTMENT ID ELEVATION

Sign Type Code

**MID**

Sheet No.

**01.0**

**WEIDNER**  
ARCHITECTURAL  
SIGNAGE

5001 24th Street  
Sacramento CA 95822  
**916.452.8000**  
Fax 916.452.3331  
CA Lic. #559090  
NV Lic. #0040109

Project  
**Legacy • Walnut Creek**  
1555 RIVIERA AVENUE  
WALNUT CREEK, CA

Company  
Legacy Partners Residential

Work Order  
**31438**

Drawn By  
**DP**

Date  
09-25-08

Phase  
Permit Submittal

Revisions No.	Date	Phase	By
▲			
▲			
▲			
▲			
▲			
▲			
▲			
▲			
▲			
▲			

© Weidner Architectural Signage - No part of the above drawing(s), design, arrangements or ideas hereon shall be duplicated or used for any purpose whatsoever without the expressed written permission of the copyright holder.

Sign Type Description  
WALL MOUNTED ILLUMINATED  
APARTMENT ID ELEVATION

Sign Type Code

**MID**

Sheet No.

**01.1**

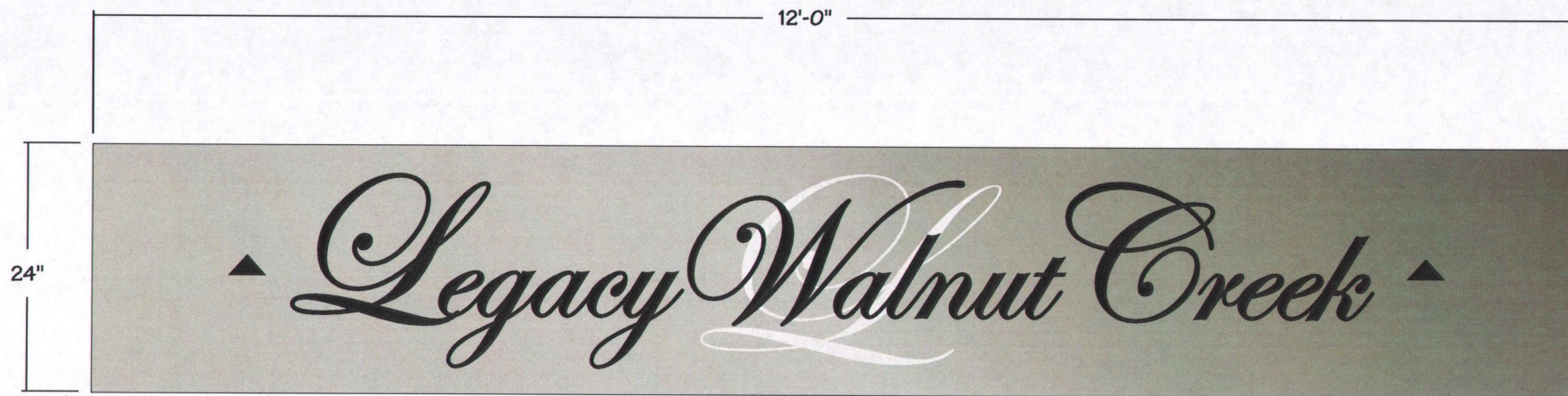

**A** ELEVATION  
SCALE: 3/4" = 1'-0"

NOTE: "LEGACY WALNUT CREEK" COPY STROKE WIDENED TO ALLOW FOR PROPER COPY "PUSH-THRU" AND ILLUMINATION

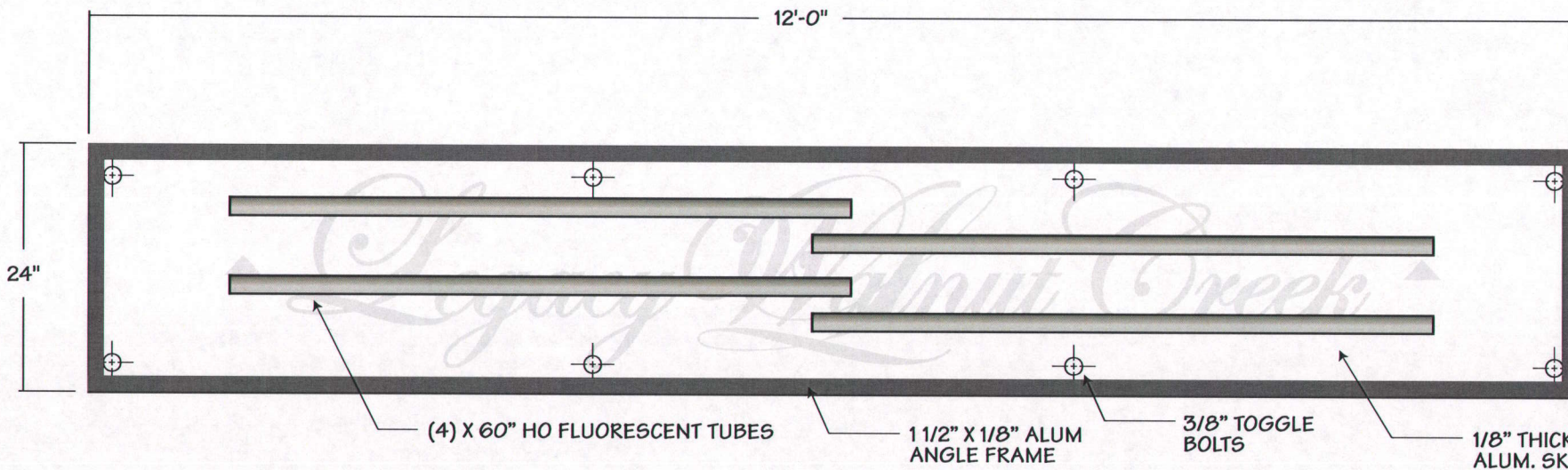

**C** ELEVATION  
SCALE: 3/4" = 1'-0"

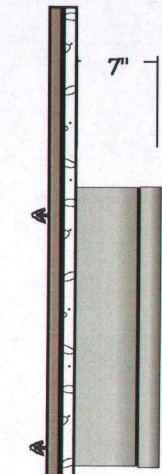

**B** SIDE VIEW  
SCALE: 3/4" = 1'-0"

STUCCO  
WOOD BACKING

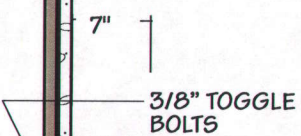

**D** SIDE VIEW  
SCALE: 3/4" = 1'-0"

"SHOE BOX"  
FACE PANEL REMOVABLE  
FOR INSTALL AND SERVICE  
RETAINED USING COUNTERSUNK  
SCREWS PAINTED TO MATCH CABINET

QUANTITY	MATERIALS	COLORS / FINISHES	TYPEFACES	INSTALLATION	PRODUCTION APPROVAL
1 SIGN CABINET- COPY AS SHOWN	7" DEEP FABRICATED ALUMINUM CABINET WITH REMOVABLE "SHOE BOX" FACE PANELS SECURED TOP AND BOTTOM USING COUNTERSUNK SCREWS PAINTED TO MATCH CABINET  FLUORESCENT ILLUMINATION	CABINET: ALL VISIBLE SURFACES PAINTED TO MATCH MATTHEWS BRUSHED ALUMINUM  LETTERS: FACES BLACK AND RETURNS CLEAR ACRYLIC  LOGO "L" PEARL GREY VINYL	(LOGO AS PROVIDED)	INSTALL TO EXTERIOR STUCCO WALL USING TOGGLE BOLTS  120V CIRCUIT TO BE PROVIDED AT SIGN LOCATIONS BY OTHERS  REMOVAL OF EXISTING SIGNS AND WALL REPAIR BY OTHERS	

**WEIDNER**  
ARCHITECTURAL  
SIGNAGE

5001 24th Street  
Sacramento CA 95822  
**916.452.8000**  
Fax 916.452.3331  
CA Lic. #559090  
NV Lic. #0040109

Project  
**Legacy • Walnut Creek**  
1555 RIVIERA AVENUE  
WALNUT CREEK, CA

Company  
Legacy Partners Residential

Work Order  
**31438**

Drawn By  
**DP**

Date  
09-25-08

Phase  
Permit Submittal

Revisions No.	Date	Phase	By

© Weidner Architectural Signage - No part of the above drawing(s), design, arrangements or ideas hereon shall be duplicated or used for any purpose whatsoever without the expressed written permission of the copyright holder.

Sign Type Description  
WALL MOUNTED ILLUMINATED  
RETAIL TENANT ID

Sign Type Code  
**MID-W**

Sheet No.  
**02.0**

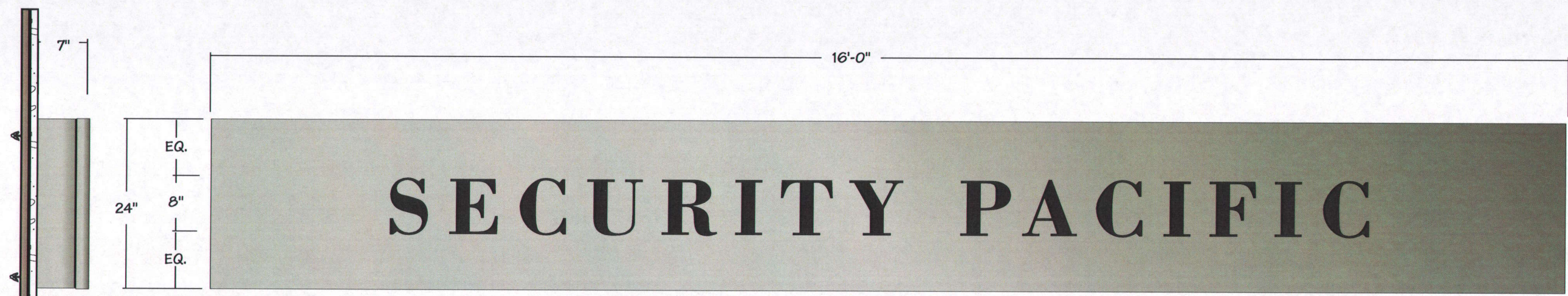

**B** SIDE VIEW  
SCALE: 3/4" = 1'-0"

**A** ELEVATION  
SCALE: 3/4" = 1'-0"

STUCCO  
WOOD BACKING

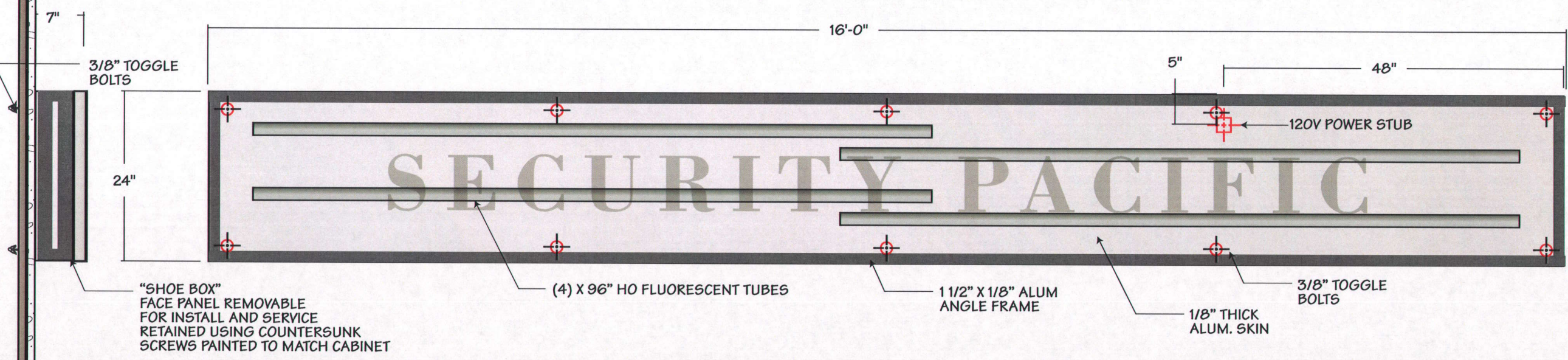

**D** SIDE VIEW - DETAILS  
SCALE: 3/4" = 1'-0"

**C** ELEVATION - DETAILS  
SCALE: 3/4" = 1'-0"

"SHOE BOX"  
FACE PANEL REMOVABLE  
FOR INSTALL AND SERVICE  
RETAINED USING COUNTERSUNK  
SCREWS PAINTED TO MATCH CABINET

(4) X 96" HO FLUORESCENT TUBES

1 1/2" X 1/8" ALUM  
ANGLE FRAME

1/8" THICK  
ALUM. SKIN

3/8" TOGGLE  
BOLTS

120V POWER STUB

QUANTITY	MATERIALS	COLORS / FINISHES	TYPEFACES	INSTALLATION	PRODUCTION APPROVAL
7 SIGN CABINETS	7" DEEP FABRICATED ALUMINUM CABINET WITH REMOVABLE "SHOE BOX" FACE PANELS SECURED TOP AND BOTTOM USING COUNTERSUNK SCREWS PAINTED TO MATCH CABINET  FLUORESCENT ILLUMINATION	CABINET: ALL VISIBLE SURFACES PAINTED TO MATCH MATTHEWS BRUSHED ALUMINUM  LETTERS: FACE PANELS BY RETAIL TENANT SIGN STANDARD FACE TO BE ROUTED - PUSH THRU 1/2" NET  LETTERING TO HAVE CLEAR RETURNS WITH OPAQUE - DURANODIC FACES	BODONI BOLD	INSTALL TO STUCCO OVER WOOD WALL USING TOGGLE BOLTS  120V CIRCUIT TO BE PROVIDED AT SIGN LOCATIONS BY OTHERS  REMOVAL OF EXISTING SIGNS AND WALL REPAIR BY OTHERS	

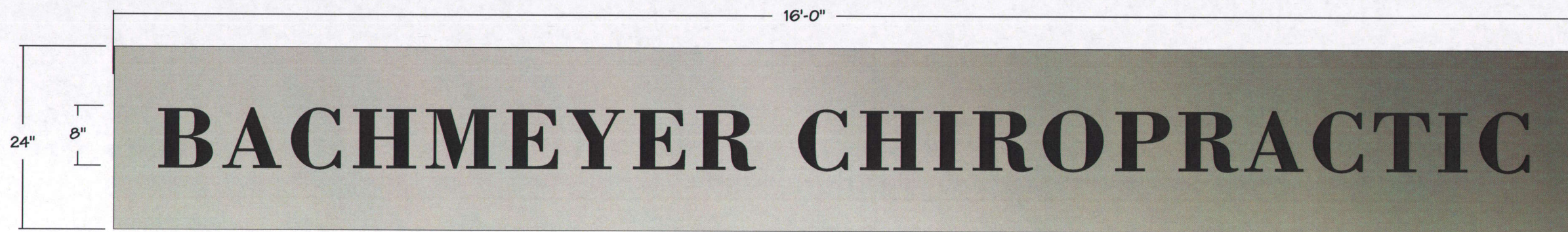

**A** ELEVATION  
SCALE: 3/4" = 1'-0"

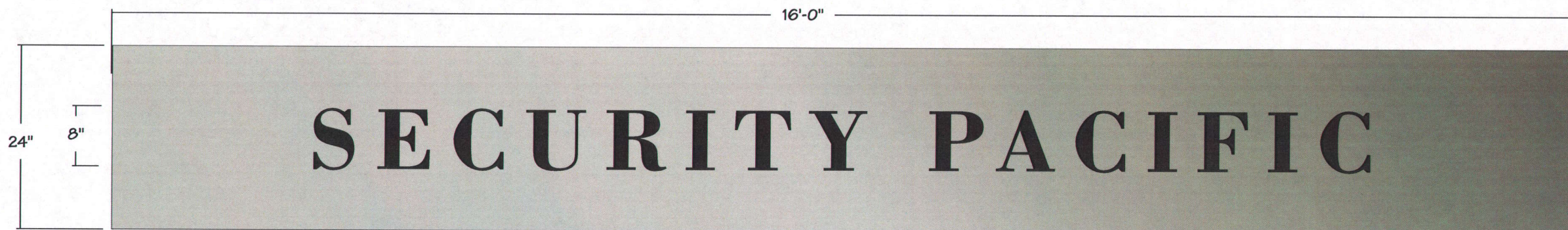

**B** ELEVATION  
SCALE: 3/4" = 1'-0"

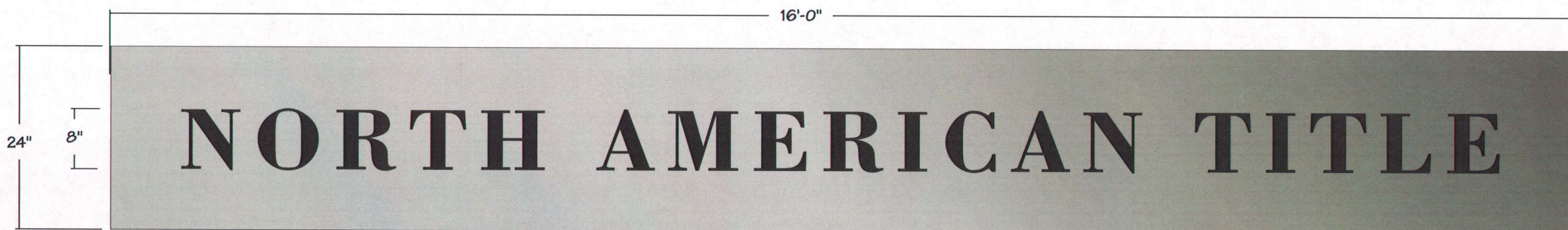

**C** ELEVATION  
SCALE: 3/4" = 1'-0"

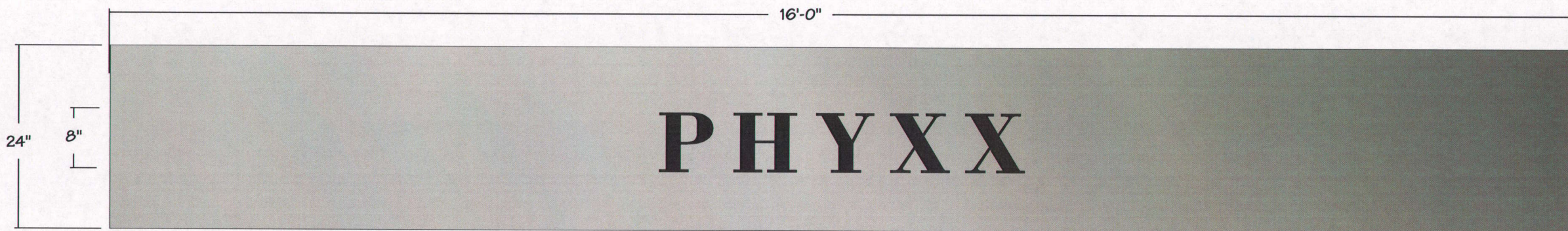

**D** ELEVATION  
SCALE: 3/4" = 1'-0"



5001 24th Street  
Sacramento CA 95822  
**916.452.8000**  
Fax 916.452.3331  
CA Lic. #559090  
NV Lic. #0040109

Project  
**Legacy • Walnut Creek**  
1555 RIVIERA AVENUE  
WALNUT CREEK, CA

Company  
Legacy Partners Residential

Work Order **31438** Drawn By **DP**

Date **09-25-08** Phase **Permit Submittal**

Revisions No.	Date	Phase	By
▲			
▲			
▲			
▲			
▲			
▲			
▲			
▲			
▲			
▲			

© Weidner Architectural Signage - No part of the above drawing(s), design, arrangements or ideas hereon shall be duplicated or used for any purpose whatsoever without the expressed written permission of the copyright holder.

Sign Type Description  
WALL MOUNTED ILLUMINATED  
RETAIL TENANT ID  
TENANT LAYOUTS

Sign Type Code  
**MID-W**

Sheet No.  
**02.1**

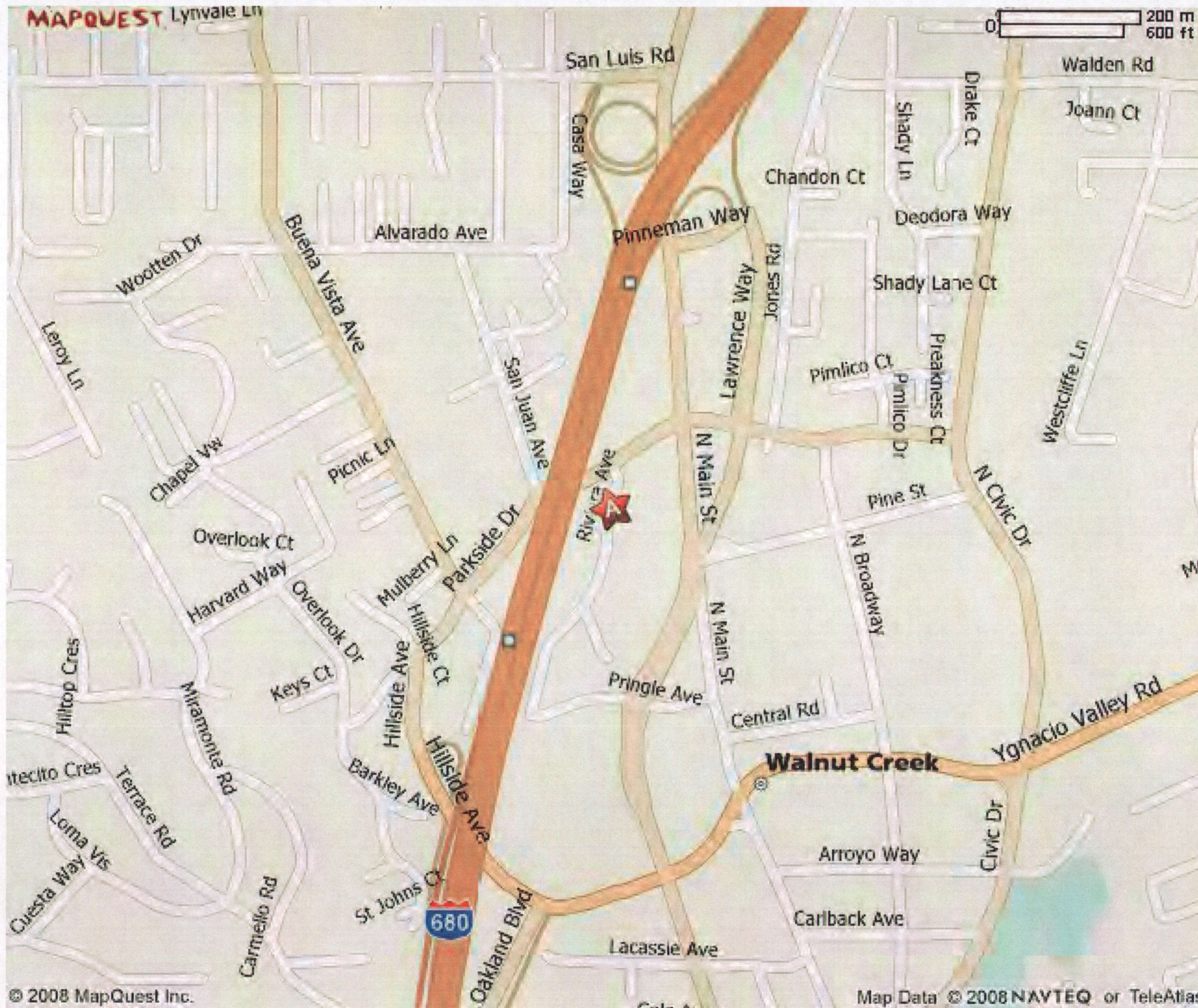

**WEIDNER**  
ARCHITECTURAL  
**SIGNAGE**

5001 24th Street  
Sacramento CA 95822  
**916.452.8000**  
Fax 916.452.3331  
CA Lic. #559090  
NV Lic. #0040109

Project  
**Legacy • Walnut Creek**  
1555 RIVIERA AVENUE  
WALNUT CREEK, CA

Company  
Legacy Partners Residential

Work Order  
**31438**

Drawn By  
**DP**

Date  
07-3-08

Phase  
Submittal

Revisions No.	Date	Phase	By
▲			
▲			
▲			
▲			
▲			
▲			
▲			

© Weidner Architectural Signage - No part of the above drawing(s), design, arrangements or ideas herein shall be duplicated or used for any purpose whatsoever without the expressed written permission of the copyright holder.

Sign Type Description  
LOCATION MAP

Sign Type Code

**MAP**

Sheet No.  
**L1.0**



**WEIDNER**  
ARCHITECTURAL  
SIGNAGE

5001 24th Street  
Sacramento CA 95822  
**916.452.8000**  
Fax 916.452.3331  
CA Lic. #559090  
NV Lic. #0040109

Project  
**Legacy • Walnut Creek**  
1555 RIVIERA AVENUE  
WALNUT CREEK, CA

Company  
Legacy Partners Residential

Work Order  
**31438**

Drawn By  
**DP**

Date  
09-2508

Phase  
Permit Submittal

Revisions No.	Date	Phase	By
▲			
▲			
▲			
▲			
▲			
▲			
▲			
▲			

© Weidner Architectural Signage - No part of the above drawing(s), design, arrangements or ideas herein shall be duplicated or used for any purpose whatsoever without the expressed written permission of the copyright holder.

Sign Type Description  
**LOCATION ARIEL**

Sign Type Code  
**ARIEL**

Sheet No.  
**L2.0**





5001 24th Street  
 Sacramento CA 95822  
**916.452.8000**  
 Fax 916.452.3331  
 CA Lic. #559090  
 NV Lic. #0040109

Project  
**Legacy • Walnut Creek**  
 1555 RIVIERA AVENUE  
 WALNUT CREEK, CA

Company  
 Legacy Partners Residential

Work Order  
**31438**

Drawn By  
**DP**

Date  
 09-25-08

Phase  
 Submittal

Revisions No.	Date	Phase	By
▲			
▲			
▲			
▲			
▲			
▲			
▲			

© Weidner Architectural Signage - No part of the above drawing(s), design, arrangements or ideas herein shall be duplicated or used for any purpose whatsoever without the expressed written permission of the copyright holder.

Sign Type Description  
 LOCATION PLAN

Sign Type Code

**LOC**

Sheet No.

**L3.0**

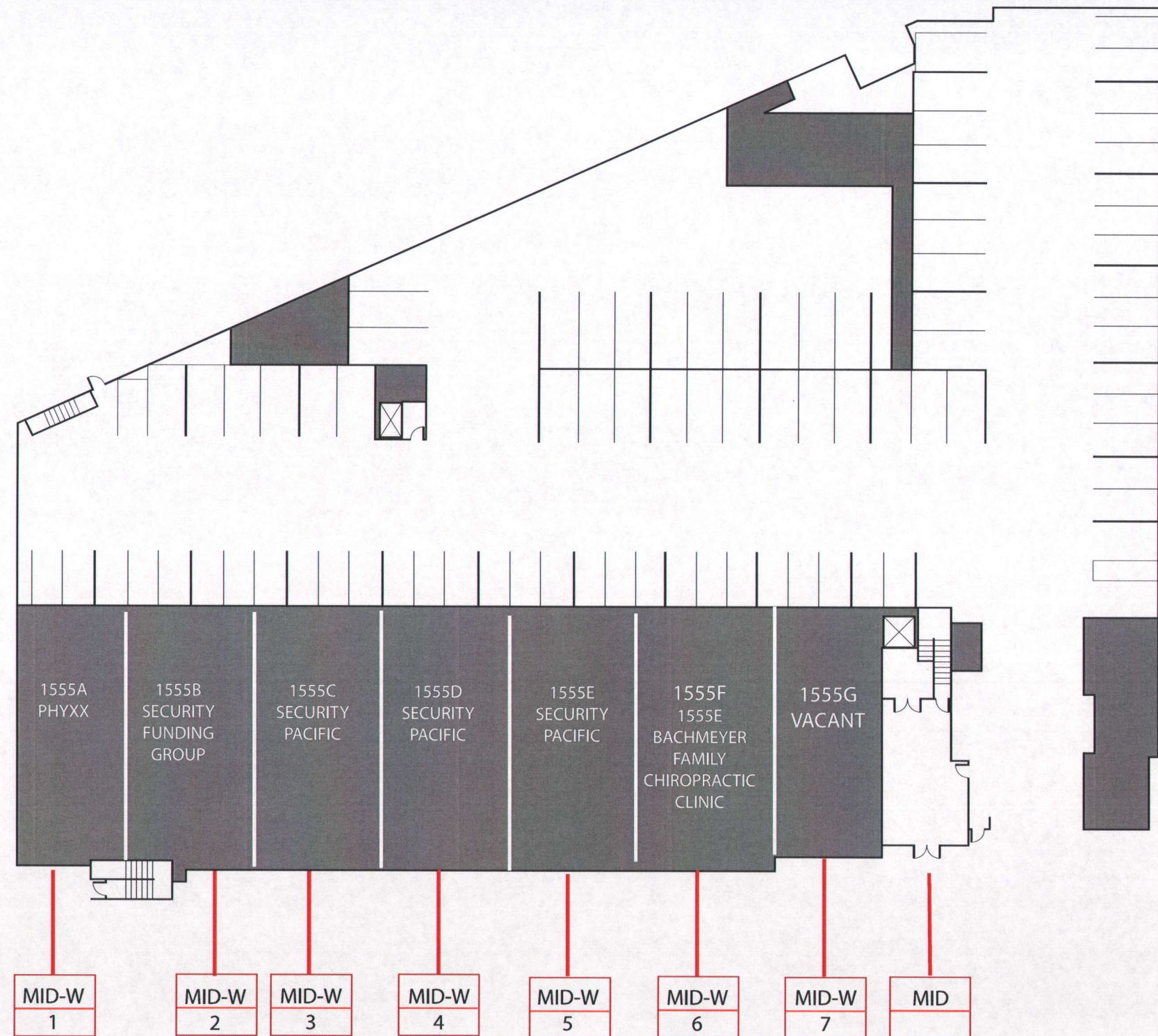

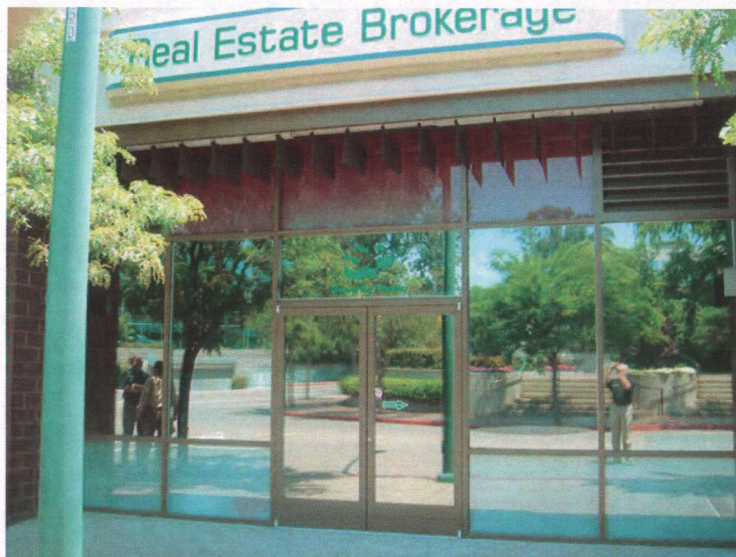

**WEIDNER**  
ARCHITECTURAL  
**SIGNAGE**

5001 24th Street  
Sacramento CA 95822  
**916.452.8000**  
Fax 916.452.3331  
CA Lic. #559090  
NV Lic. #0040109

Project  
**Legacy • Walnut Creek**  
1555 RIVIERA AVENUE  
WALNUT CREEK, CA

Company  
Legacy Partners Residential

Work Order      Drawn By  
**31438**              **DP**

Date              Phase  
09-25-08      Permit Submittal

Revisions No.	Date	Phase	By

© Weidner Architectural Signage - No part of the above drawing(s), design, arrangements or ideas herein shall be duplicated or used for any purpose whatsoever without the expressed written permission of the copyright holder.

Sign Type Description  
TENANT FRONTS  
PHOTOGRAPHS

Sign Type Code

**TENANTS**

Sheet No.  
**L4.0**